

# RAB2000 Dev Board

## Rapid Rabbit Prototyping Board

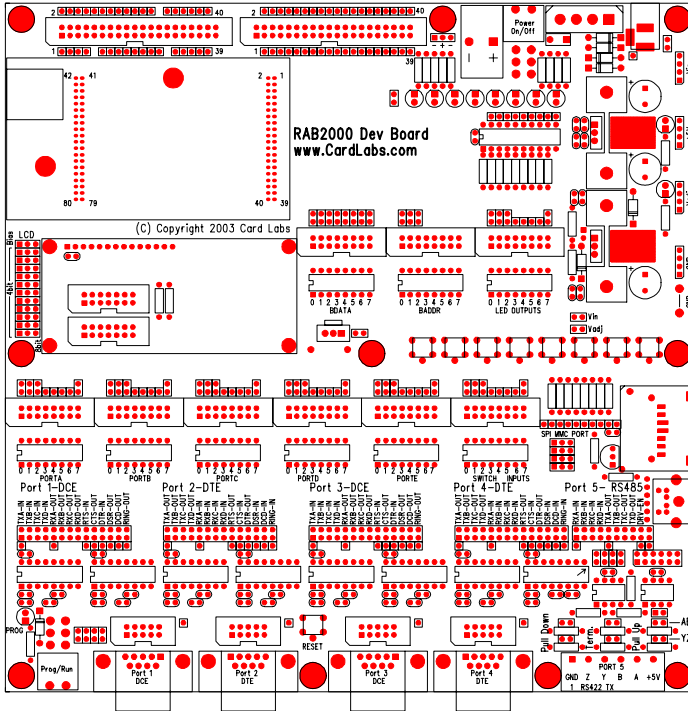

The RAB2000 development board provides an easy way to use the IO and serial ports of the Rabbit Semiconductor RCM2100 family of core modules.

### Features

Through-hole construction allows for easy customization, modification, and maintenance.

Headers allow IO signals to be easily reconnected with jumper blocks or wires. Test points give good access to signals and provide solder points for wires.

All RCM2100 core module signals are available on two 2x20 headers with 0.1" spacing.

All port signals are available on 2x8 headers and DIP16 sockets for easy connection via ribbon cables.

All headers are populated with unshrouded headers to give easy access to them as test points. However, the board footprints provide enough room for polarized connectors to be installed.

ICs are installed in sockets for easy replacement.

### Indicators

+5V LED, +3V3 LED (optional),  
Program/Run LED,  
Eight Output LEDs (optional)

### Switches

Power Switch,  
Program/Run Switch,  
Reset Button,  
Eight Input Buttons (optional)

### Connectors

Power In:	2.1mm Barrel
RCM2100:	Two 2x20 Headers (2mm)
RCM2100 Signals:	Two 2x20 Headers (0.1")
Ports 1 & 3, DCE:	DB9 Female
Ports 2 & 4, DCE:	DB9 Male
IO Ports A,B,C,D,E:	Five 2x8 Headers & DIP16
Data & Address:	Two 2x8 Headers & DIP16
Battery:	CR2032 Coin & 3 Pin Header

### Optional Connectors

Port 5, RS485/422:	6 Position Removable Terminal Block
Keys In, LEDs Out:	2x8 Headers & DIP16
LCD / VFD:	1x14 Header, 2x8 Header 2x8 Header Rev. Pinout
Serial Dataflash:	Multi-media Card
Not Installed:	Mini-DIN 6, Molex Power, LCD Backlight

### Specifications

Input Voltage:	9 to 15 VDC (either polarity)
Size:	8.5" x 8.5"

### Accessories

RCM2100 RabbitCore module is sold separately.  
Optional serial dataflash multi-media card,  
2, 4, or 8 megabytes.  
Optional 2x16 character LCD or VFD.  
Optional +12V wall adapter.



132 Harvest Park Way NE, Calgary, Alberta, Canada T3K 4K7  
Tel: (403) 567-9328 Fax: (403) 567-9329  
[www.cardlabs.com](http://www.cardlabs.com) [sales@cardlabs.com](mailto:sales@cardlabs.com)

## **RAB2000 Development Board Details**

This brochure describes all of the features and options available on the RAB2 Development Board. Various versions of the board are available with different features installed.

### **Core Module Connectors**

The 2mm core module connectors are brought out to two 0.1" headers for easy connection to other boards. Each RCM2100 signal also has a test point for a wire soldering point.

### **Port Connectors**

Each 8 bit Rabbit port is brought out to a separate DIP16 socket and 2x8 header as are the buffered data and buffered address (BA0-BA12) lines.

The DIP16 socket allows a DIP16 ribbon cable to be used connect the port to a solderless breadboard.

The 2 x 8 header is unshrouded which allows it to be used for test points or connection to a ribbon cable.

Jumpers can be added to provide any of the supply voltages and ground to the port connectors.

PORTE strobe lines are brought out to the buffered data connectors. BBUFEN, BIORW, and BIORA are brought out to the buffered address connectors.

### **Four RS232 Drivers**

Two DCE and two DTE serial ports are provided, each with DB9 connectors.

Any Rabbit serial port (A, B, C, or D) can be connected to any serial port driver (1, 2, 3, 4) by moving jumpers.

Each of the four serial ports has a 2 x 5 header that can be used as test points or to connect a ribbon cable. The signals on the header are arranged so they will be in the correct order if a ribbon cable goes from the header to a DB9 IDC connector. An unshrouded connector is populated to provide access to the pins as test points.

Operation with two RS232 driver chips per port allows full serial port handshaking, allowing hardware flow control. The RCM2100 has enough IO pins to provide full handshaking on one DCE port and one DTE port.

### **Built-in Programming Port**

Serial port 1 can be used as a Rabbit programming port without the need to use the Rabbit programming cable.

A switch allows quick changes between program and run modes without the need to unplug cables.

An LED indicates when the board is in program mode.

### **RS485/RS422 Driver**

Serial port 5 can be used for RS485 (half duplex, 2 data lines) or RS422 (full duplex, 4 data lines).

Any Rabbit serial port (A, B, C, or D) can be connected to serial port 5 by moving jumpers.

The 6 position removable terminal block gives A & B signals (RS485), X & Y signals (for RS422) and +5V and ground.

Termination resistors and pull-up, pull-down resistors can be connected by moving jumpers.

An isolation header allows opto-couplers and power isolation circuitry to be installed for isolated RS485 ports. This is not presently provided by Card Labs.

### **Character LCD Interface**

A 2x16 character VFD or LCD can be mounted on the PCB with a 1x14 header.

Two 2x7 connectors are provided to connect to a LCD with ribbon cable. One has a reverse pinout for connecting to the back of an LCD. A resistor footprint is provided for an LED backlight.

Jumpers allow the LCD to be connected in bi-directional 8 bit mode or 4-bit write only mode to save IO pins.

### **RTC/NVRAM Battery**

A holder for a 2032 size coin is provided on the board. A 3 pin header is provided for an off-board battery (2.85 V to 3.15 V).



132 Harvest Park Way NE, Calgary, Alberta, Canada T3K 4K7  
Tel: (403) 567-9328 Fax: (403) 567-9329  
[www.cardlabs.com](http://www.cardlabs.com) [sales@cardlabs.com](mailto:sales@cardlabs.com)

## **Reset Switch**

A momentary pushbutton reset switch is provided.

## **Serial Dataflash Multi-Media Card**

A multi-media card socket for Atmel AT45DCB00x serial Dataflash cards is an option. Dataflash cards are available in 2, 4, and 8 megabyte sizes.

Jumpers allow the card to be connected in SPI mode or port mode. Port mode frees up a serial port.

## **8 Debug LEDs**

The LEDs can be connected to a Rabbit port connector with a ribbon cable.

The 74HC541 octal buffer can be replaced with a 74HC574 octal latch to provide a latching output with only a few wires. Note: there is a difference in the output pin numbering between these two ICs.

## **8 Input Switches**

Eight momentary pushbutton switches are provided with pull up resistors.

The switches can be connected to a Rabbit port connector with a ribbon cable if an entire 8 bit input port is available for use. Port A can be set to all inputs on RCM2100 modules. Ports D or E can also be used for non-ethernet core modules.

Jumper wires can be used to connect switches to individual inputs if an entire 8 bit input port is not available.

## **Power Supply**

A power switch allows the board to be turned off without unplugging cables.

A bridge rectifier allows either DC power polarity to be used.

A +5V regulator provides power to the board. A heatsink allows extra current for test circuitry.

A +3V3 regulator is provided when the serial data flash card is installed. It may be set to other voltages by changing resistors. A PCB footprint for a heatsink is provided to allow higher output current (heatsink not installed for the dataflash option).

## **Mini DIN 6 Connector**

A Mini-DIN6 connector footprint is provided for interfacing or for keyboard or mouse experiments. It is connected to test points. No interface circuitry is provided on board.

## **RAB2000 Models Available**

### **Model 100**

The Model 100 version of the development board has the minimal parts to develop RS232 applications. Only one of the two MAX202 drivers is installed for each serial port.

- RCM2100 access headers (0.1" pitch)
- IO port connectors
- Four RS232 drivers, two DCE and two DTE (2 handshake lines each)
- DB9 connectors for RS232
- Rabbit programming switch for DCE serial port 1
- +5V voltage regulator with heatsink

**Order #: PCA-9/100**

### **Model 200**

The Model 200 version of the development board adds additional MAX202 drivers to allow full handshaking on the RS232 ports. The RCM2100 has enough IO to do full handshaking on two ports. The input switches, output LEDs, and LCD connectors are populated. The RS485/422 driver is also added.

- All model 100 features plus...
- 8 switch inputs, 8 LED outputs
- LCD connectors (1x14 and two 2x7)
- Four additional RS232 driver ICs for full handshaking on serial ports
- RS485/422 drivers, full or half duplex, with removable terminal block
- Two DIP16 ribbon cables and eight jumper wires

**Order #: PCA-9/200**

### **PCB Only**

A bare RAB2000 PCB can be purchased so that you can populate it yourself. A full BOM is available providing all manufacturer's part numbers.

**Order #: PCB-9**



132 Harvest Park Way NE, Calgary, Alberta, Canada T3K 4K7  
Tel: (403) 567-9328 Fax: (403) 567-9329  
[www.cardlabs.com](http://www.cardlabs.com) [sales@cardlabs.com](mailto:sales@cardlabs.com)